

START

1 Slide in monitor

Open the device and gently slide the screen side under the top side clips on case until all 3 sides are secure.

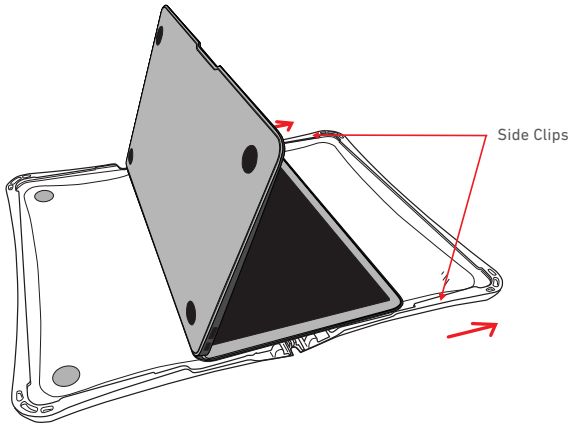

2 Press in keyboard

With the device in upright position, press the sides of the keyboard down into the case until securely attached—pressed into the side clips.

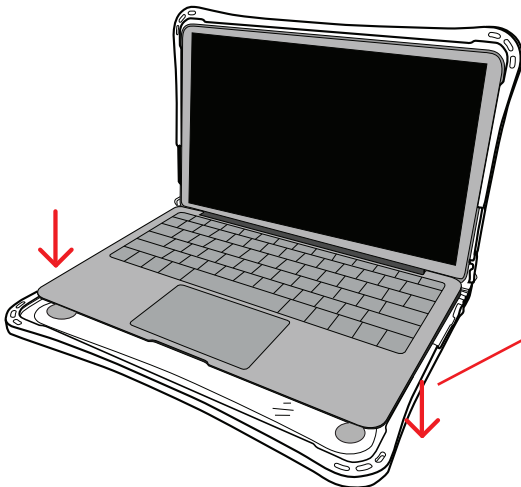

3 Ensure both sides are fully inserted

Close the assembled case and device, and press the bottom edges down onto a solid surface to ensure the device is fully seated in the case.

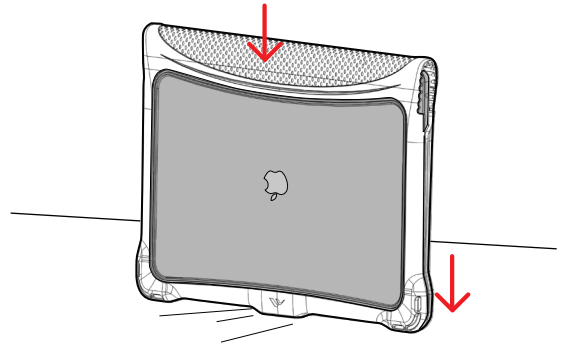

Troubleshooting Tips

- Ⓐ If inserting keyboard edge is too tight, flex the corners of the case a few times, and insert front edge of keyboard into the recessed channel on the left/right case sides

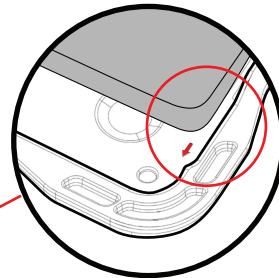

- Ⓑ If latch does not operate smoothly or securely, repeat step #3 to ensure fitment.

START

1 Release keyboard side

Press downward on 2 bottom corner crumple zone areas

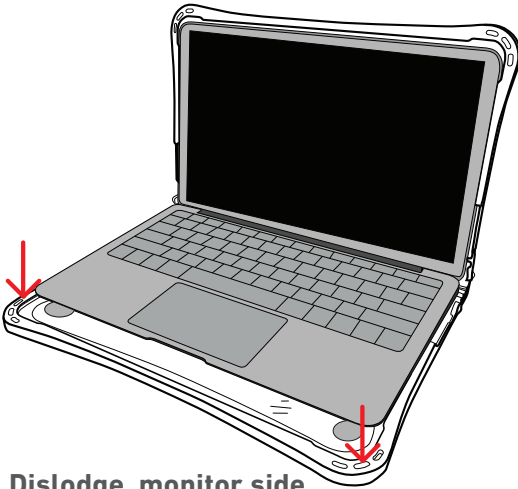

2 Dislodge monitor side

Use your fingers behind the hinge of the device/case to slide the case up a few inches to dislodge it.

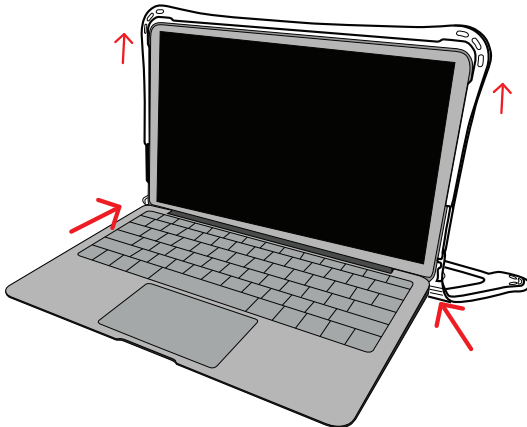

3 Ensure both sides are fully inserted

With the monitor side of the case slid up a few inches, it can now be grabbed and fully slid off.

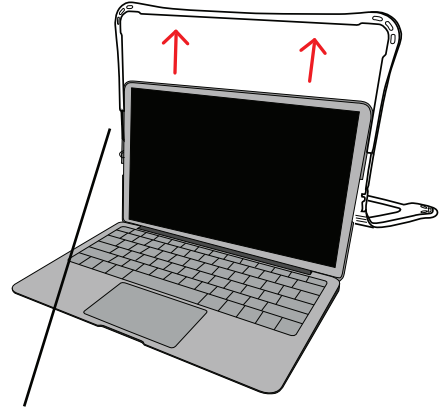

CRITICAL!

The monitor must be SLID out of the case. Failure to do so through forcefully popping/pressing the monitor out may cause damage to the device.